

F 228

VERY SIMILAR IN ITS DYNAMIC AND MECHANICAL CHARACTERISTICS TO THE CONCERT GRAND (F278); A DEEP AND POWERFUL BASS MAKES THIS PIANO EXCELLENT FOR MEDIUM-SIZE CONCERT HALLS. ONLY SLIGHTLY SMALLER THAN A FULL CONCERT GRAND, ITS RICHNESS IN TIMBRE MAKES IT AN IDEAL INSTRUMENT FOR CHAMBER MUSIC OR SOLO REPERTOIRE.



DIMENSIONS

1000 mm / 1550 mm / 2280 mm

WEIGHT 415 Kg

SOUNDTABLE

Red Spruce from Val di Fiemme - Italy

KEYBOARD, RENNER ACTION AND HAMMERS

Built according to Fazioli specifications

BLACK KEYS Ebony wood

WHITE KEYS Non-slippery and non-reflecting composite material

PEDALS

Sustain, tonal, soft (una corda)

FINISH

Black high-gloss polyester finish or other choices

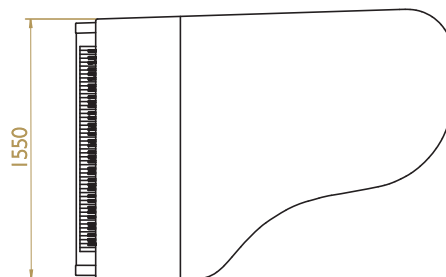
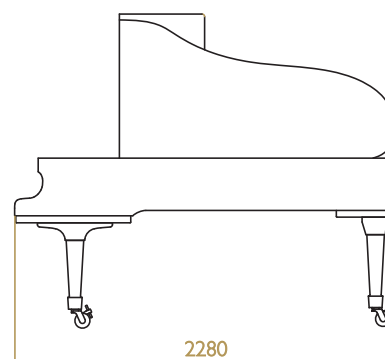
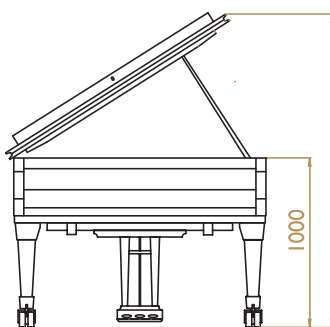

FAZIOLI

RIMS

The rims are made by stacking together 5mm thick lengths of solid wood, which is then bent around special moulds to form its characteristic shape. For the model F228 the inner rim is made of 9 layers of solid maple and the outer rim of 7 layers of solid mahogany.

At the Fazioli factory, rims are still shaped in the time honoured method which leaves the wood in the clamps for days in order to adapt to its new shape; this method allows the glue to dry naturally rather than artificially assisting the process. In this way, the natural tendencies of the wood are respected and it creates a condition that will ensure the stability and longevity of the piano for years to come. The rims are then left to "rest" for a period of not less than 6 months before further assembly can commence.

SOUNDBOARD

The soundboard is made entirely of red spruce, which comes from the Val di Fiemme, a valley in the eastern Italian Alps. Evenness, lightness and flexible strength are typical features of this wood, the same that Stradivari chose for his legendary violins. The soundboard is made by laying several lengths of red spruce, cut from the trunk using the quarter sawn method, side-by-side and gluing them together. After passing a rigorous selection process the 1cm thick lengths, which are between 8 and 12cm wide, are chosen by the highly specialised Fazioli technicians. Before being glued together, the lengths are planed by hand to ensure that they fit together seamlessly. The gluing takes place using the time honoured manual clamping system which is still considered the best way of obtaining precise results. After gluing the board is shaped and the excess wood is removed. Both sides are then leveled and polished using a special calibrating machine to ensure they are perfectly parallel. Finally, the board is left to rest for at least three years in a climate controlled room which rigorously maintains the ideal conditions of humidity and temperature.

RIBS

In order to reinforce the sound board small crosspieces known as ribs, which are also made of red spruce, are attached perpendicularly to the grain. They are glued on using a special pneumatic press, which has been designed specifically to ensure perfect adhesion between the ribs, the board and the mould.

For the model F228, 14 supporting ribs are attached to the underneath of the soundboard.

SOUNDBOARD DOUBLE CURVATURE

The two bridges are glued onto the board simultaneously using a special press; by compressing them on a purpose-made mould the board obtains its "double curvature". At the end of this process, the board looks slightly convex, similar to the surface of a spherical cap with a wide radius.

BRIDGES

The bridges are made of thin strips of maple wood and mahogany glued together. The top of the bridge is laminated using woods with different qualities and increasing hardness proportionate to the frequency of the strings: maple is the wood of preference for the base and the centre areas, hornbeam for the treble and boxwood for the high treble.

The notch at the top of the bridges is entrusted to the masterly ability of the most expert craftsmen. The notches are cut vertically so that the strings are completely free from the point they leave the bridge pins.

PIN BLOCK

The pin block is the part into which the steel tuning pins are inserted. The stability and strength of the pin block is fundamentally important for the stability of the tuning. For the F228 model the pin block is made of 7 layers of hard rock maple glued together at extremely high pressure using phenolic glue. The pin block must fit perfectly into its housing, which is positioned below the front crosspiece of the iron frame. This is a very delicate operation carried out manually by expert technicians to ensure the utmost precision.

STRINGS

The white strings are made of harmonic steel from Röslau Blau and the bass strings are in harmonic steel with copper wound (copper from Degen).

DUPLEX SCALE SYSTEM

The back portion of the string, known as the resonator, is isolated from the part of the string hit directly by the hammer. The resonator vibrates in sympathy to the note struck, this is called the duplex scale. In Fazioli pianos, the duplex scale is completely adjustable because of a system that enables the length of the resonator to be modified. This system enables the resonator to be tuned to the finest detail.

IRON FRAME

The iron frame is conceived in order to resist the tension produced by the strings, which is between 19-21 tons. For this reason the frame design must be made with particular attention to the stress points where the force is more concentrated. The iron frame of a Fazioli piano is produced by the traditional "sand casting" method. This method must be carried out by highly skilled and experienced artisans. This type of casting delivers acoustically superior results compared with the modern automated systems. It is smoothed, sanded and sprayed with several coats of special metallic gold lacquer.

KEYBED

The keybed is a wooden frame made of three beech-laminated rails and two large solid crossbars at the edge. This construction gives the keybed maximum stability. It is important that the keybed remains completely flat so that the key frame stays in contact with it without interference or stresses coming from the front legs, which are attached to the keybed. The area between the keybed rails is filled with laminated red spruce, the same wood used for the soundboards. In order to improve the movement of the key frame when the left pedal is used, the "key frame glides" on Teflon inserts.

ACTION

The action of a piano is made up of thousands of parts, each of which contributes to turning the movement of the pianist's fingers into sound. Three main parts form this complex and delicate mechanism: the action, the keyboard and the hammers. Our actions are made to our own FAZIOLI specifications by the most reputable specialists in the field. Fazioli uses Renner actions and hammers and Kluge keyboards. The wippens and the hammer shanks are made of hornbeam wood, which is extremely strong and stable. The wippen has a double spring and the profile of the repetition lever is made to our specification. The dampers have a double joint damper wippen and the wippens are actioned by an adjustable spoon.

KEYBOARD

The three key frame rails are made of maple, the front rail is shaped with a small concave curvature and the keybed has a convex curvature thus the fit between the two is perfect. The crossbars are made from spruce so that the complete key frame is elastic and will fit perfectly to the keybed without gaps that may produce noises. The keys are reinforced at the top by the "key button" which is made of maple and capstan; back checks are inserted in a beech block, which is glued to the keys. The touch weights are fixed from 48 grams at the treble to 52 grams at the bass. The up-weight, which is extremely important, is also controlled; in particular the up-weight is generally 21-23 grams in the bass and 25-26 in the treble.

HAMMERS

The wooden heart of the hammers is made from walnut, a wood that has excellent characteristics in terms of stress and impact resistance over time. The finest quality of felt is selected for the hammers in order to obtain the maximum strength and elasticity. The hammer shanks onto which the hammer head are attached, are made from hornbeam which is known for its strength and flexibility.

POLYESTER

We use the finest quality polyester applied by a complex process on a previously treated surface.

The sanding of the finished parts is almost entirely done by hand as only the sensitivity of the human hand ensures perfection is achieved on each part of the piano. The only exception is the lid, where the large surface areas are polished by an automated machine which guarantees a perfectly flat surface. The finished and sanded parts are then polished. Only the first stage of polishing uses machines, the final finish is achieved by hand.